

SHAFT ALIGNMENT

BY REVERSE INDICATOR METHOD

By

Vidhu S. Gairola

B.Sc. (Eng) in Mech Eng, M.S. in M.E.

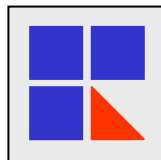

RESCO

MANUAL

SHAFT ALIGNMENT

BY REVERSE INDICATOR METHOD

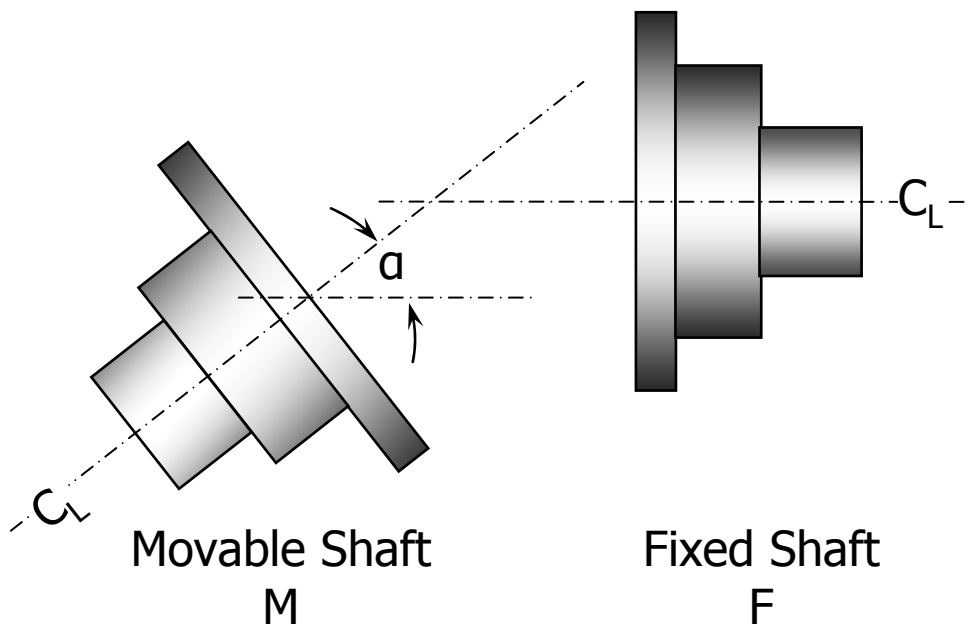

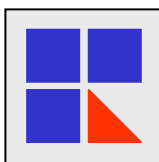

Second Edition
2005

First Edition 2000

Copyright 2005

By

RESCO Solutions, Inc.

1995 Sherwood Glen
Bloomfield Hills, MI 48302 (USA)
www.resco-solutions.com

No part of this publication can be printed or copied in any form without the prior
Written permission of the author.

PREFACE

It is heartening to see the second edition coming out. The first edition became quite popular with engineers, supervisors and workmen who are involved with the actual maintenance of rotating equipment.

Although most of the reasons for rotating equipment problems are initiated by misalignment, shaft alignment is not a subject formally taught in any engineering school. An engineer learns about the topic only with experience. There are computer programs and computerized tools in the market that are quite convenient to use. However, they are tools for use in the field and not a means to learn about the topic of shaft alignment. The quickest and surest way to learn about shaft alignment is when the aligner attempts the graphical method to achieve alignment. This method is somewhat more time consuming (the time it takes to plot the graph) than the computerized tools; but once the aligner understands the plotting mechanism, he can start to visualize the shaft misalignment trend just by looking at the dial indicator readings.

Training is a long process of repeated learning. For maximum benefit, long-term training program must be implemented. Worker training must emphasize preserving equipment reliability while maximizing production.

Although the primary method of shaft alignment that is emphasized in this manual is the 'Reverse Indicator Method', 'Face and Rim Method' is also explained in manual with the caution that the latter method should be used only when the former cannot be applied for whatever reasons.

In addition to what the first edition does, this manual some additional information about shaft alignment techniques that the author believes to be useful to the aligner in the field.

The method of alignment in the book is described in the form of simple steps that are universally applicable to various shaft alignment applications. There are examples illustrating various situations encountered in the field. There also exercises with answers that would help in the understanding of the subject. The author welcomes the reader to clarify any doubts about the subject in the field.

Bloomfield Hills, MI
January 2005

Vidhu S. Gairola
vsgairola@re-sco.com

TABLE OF CONTENTS

Shaft Alignment

Text	Description	Page
1.0	Chapter General	1
1.1	Defining Shaft Alignment	2
1.2	Use of Flexible Couplings	2
1.3	General Traits of Flexible Couplings	2
1.4	Main Reason for Poor Equipment Operation	2
1.5	Who Should Do Alignment and Why	2
1.6	Factors that Cause Alignment to Change in the Field	3
1.7	Misalignment Types	3
1.8	What Can Happen to Misaligned Equipment	4
1.9	Misalignment Symptoms During Equipment Operation	4
	Exercise on Chapter 1.0	5
2.0	Chapter Cold Alignment	6
2.1	Definitions	7
2.2	Main Steps of Cold Alignment	8
2.3	Use of Various Tools	8
2.4	Advantages of Universal Clamping Device	11
2.5	Why Magnetic Base Stands Must Never Be Used on Shaft Dia	11
2.6	Usual Procedure of Cold Alignment	12
	Exercise on Chapter on 2.0	13
3.0	Chapter Reverse Indicator Method Fundamentals	15
3.1	Reverse Indicator Method of Alignment (RIM)	15
3.2	Face and Rim Method	17
3.3	Disadvantages of Face and Rim Method	18
3.4	Advantages of Reverse Indicator Method	18
3.5	Fundamentals of Reverse Indicator Method	19
3.6	Clamp Sag Measurement	23
3.7	Soft foot Measurement and Correction	24
3.8	Coupling Hub Run out Check	25
	Exercise on Chapter 3.0	26

TABLE OF CONTENTS

Shaft Alignment

Text	Description	Page
4.0	Reverse Indicator Method (RIM) Graphical Method	27
4.1	Alignment Steps – Equipment Train Without Spacer Coupling	28
4.2	Basic Map	28
4.3	Final Plot	30
4.4	Alignment of Equipment Train With a Long Spacer	34
4.5	Multiple Equipment Train – Given Thermal Growth	37
4.6	Multiple Equipment Train – Given Desired Cold Readings-True	39
	Exercise on Chapter 4.0	42
5.0	Chapter Misalignment Tolerances	43
5.1	Misalignment Tolerances	44
	Exercise on Chapter 5.0	47
6.0	Chapter Alignment Limitations	48
6.1	Alignment Prerequisites	49
6.2	Usual Reasons of Delay in the Field	49
6.3	Reasons for Inaccuracies in Alignment Methods	49
7.0	Chapter Conclusion	51
7.1	Conclusion	52
8.0	Chapter Practice Exercises	53
8.1	Theoretical Exercises	54
8.2	Practical Exercises	56
	About the Author	58
	About RESCO	58